

PULKRA

WWW.PULKRA.IT



MANIFESTO QUADRO
BY STORMO STUDIO

MADE WITH ACRON®

180

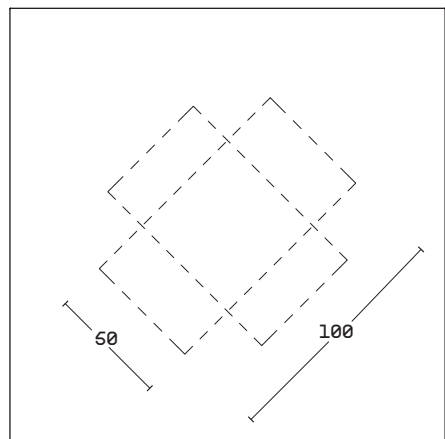

180

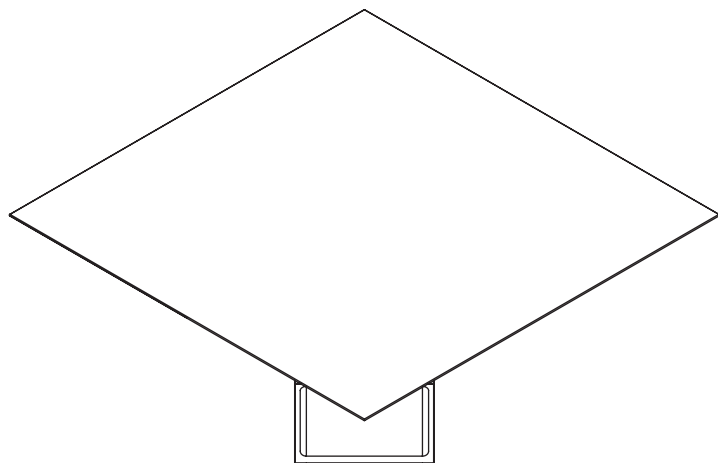

180

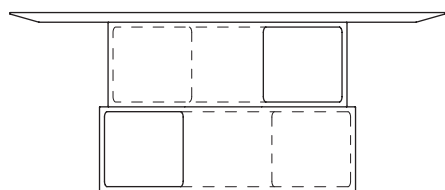

74

SKU

MNFST. QR

MISURE/SIZE

180 X 180 X H. 74

FINITURE/ FINISHES

BLACK , WHITE , ORIGIN , SOUL , RED , DESIRE , HOPE
MEMORY , TIME , PURE , MIND , LIFE

PESO/WEIGHT

480 KG

COLLI/PACKAGE

3

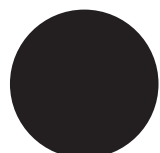

BLACK

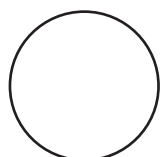

WHITE



ORIGIN
NCS S 0530-G80Y

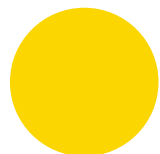

SOUL
RAL 1018



RED
NCS S 1085-Y80R

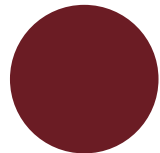

DESIRE
RAL 3004

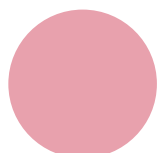

HOPE
NCS S 0520-R10B

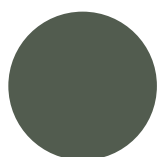

MEMORY
RAL 7009

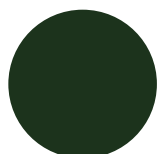

TIME
RAL 6009

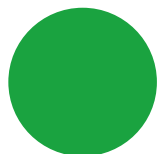

PURE
RAL 6037

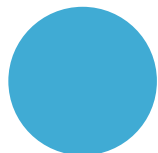

MIND
NCS S 1050-B

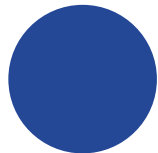

LIFE
RAL 5002

La ricerca progettuale di Stormo Studio è accompagnata costantemente dal background comune nell'ambito dell'architettura. Elena Calabrò e Michael Carion indagano l'intrinseca relazione tra spazio e materia e ricercano la fisicità nelle emozioni, lasciando che la forma risultante da questo processo sia naturalmente evocativa e significativa. Stimolati dalle potenzialità del cemento come materiale di design e cercando di sfidare la materia sino al suo limite, hanno progettato Manifesto. La collezione è ispirata alle teorie architettoniche del Metabolismo, riferendosi poi a temi ricorrenti della pratica progettuale dello studio come l'estetica del vuoto e la filosofia orientale. Manifesto si compone di tavoli in diverse dimensioni e configurazioni, caratterizzati da sostegni all'apparenza massicci, ma che in realtà si basano su un equilibrio delicato. Una sfida tecnica che ben rappresenta ricerca di Pulkra.

Everything Stormo Studio creates is informed by the designers' shared background in architecture. Elena Calabrò and Michael Carion investigate the intrinsic relationship between space and material and seek physicality in emotions, letting the form resulting from this process be naturally meaningful and evocative. Manifesto is inspired by the potential the pair saw in concrete and the challenge of seeing how far they could take it. The collection echoes the architectural theories of Metabolism, while incorporating some of the studio's recurring themes such as the aesthetics of the void and Oriental philosophy. Manifesto's tables, in different sizes and configurations, appear to rest on massive supports but in truth feature a delicate balance. A technical challenge, met by none other than Pulkra.

PULKRA

WWW.PULKRA.IT

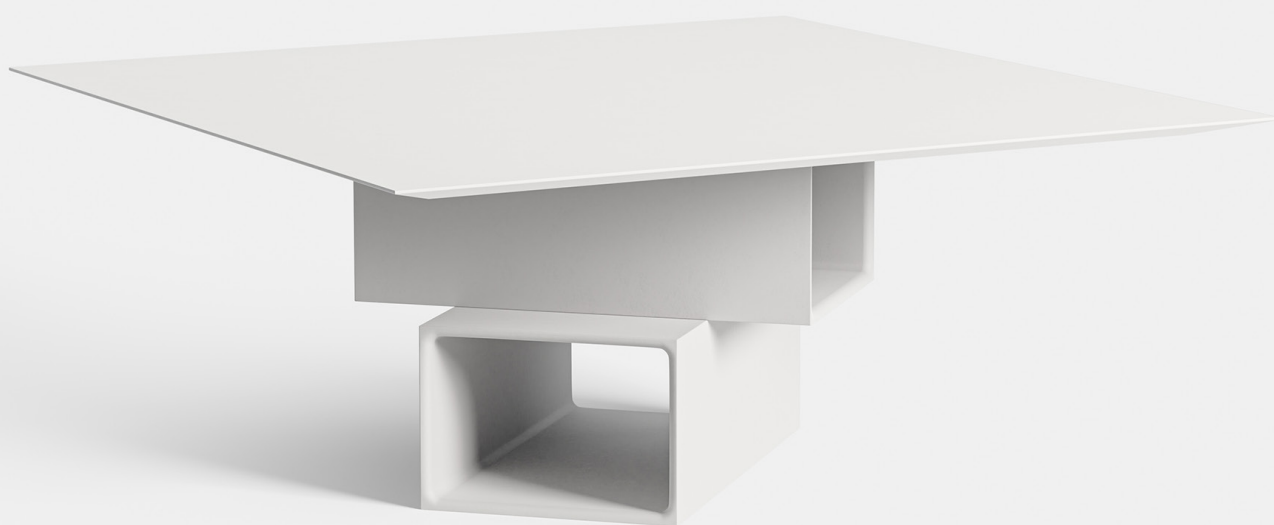

MONTAGGIO/ASSEMBLY

Si consiglia di far eseguire il montaggio a personale qualificato. Per la movimentazione delle basi sono necessarie 2 persone, per il piano 4-6 persone. Attenzione, durante la movimentazione del prodotto, onde evitare di danneggiare il prodotto, si consiglia di appoggiare sempre i diversi elementi su una superficie protettiva e di non piegare bruscamente il piano. Durante il montaggio, maneggiare il prodotto con guanti puliti.

We recommend having the assembly carried out by qualified personnel. 2 people are needed to move the bases, 4-6 people are needed for the top. Attention, when moving the product, to avoid damaging the product, we recommend always placing the various elements on a protective surface and not bending the top abruptly. During assembly, handle the product with clean gloves.

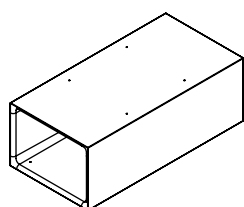

X2 BASE MODULE



X4 ADESIVE
RUBBER PADS

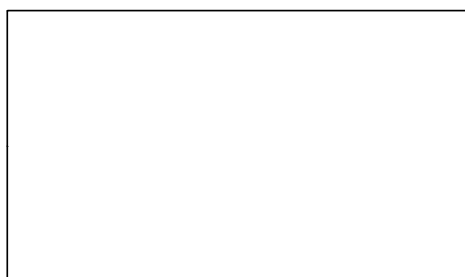

X1 TABLE TOP



X8 SCREWS

1

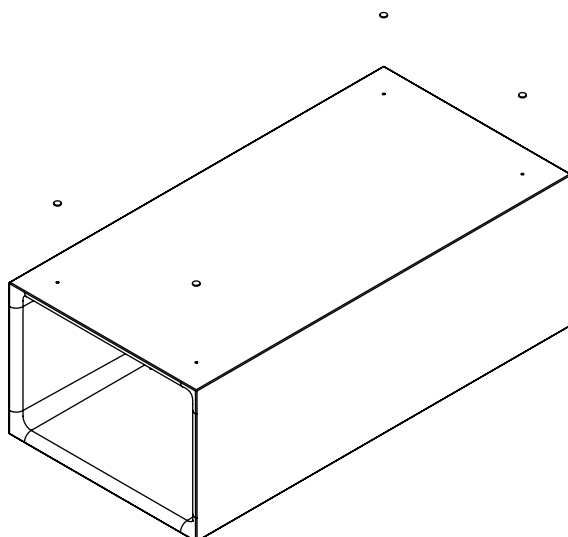

IT • RUOTARE LA BASE INFERIORE ED APPLICARE I GOMMINI PROTETTIVI.

EN • ROTATE THE LOWER BASE AND APPLY THE PROTECTIVE RUBBERS PADS.

2

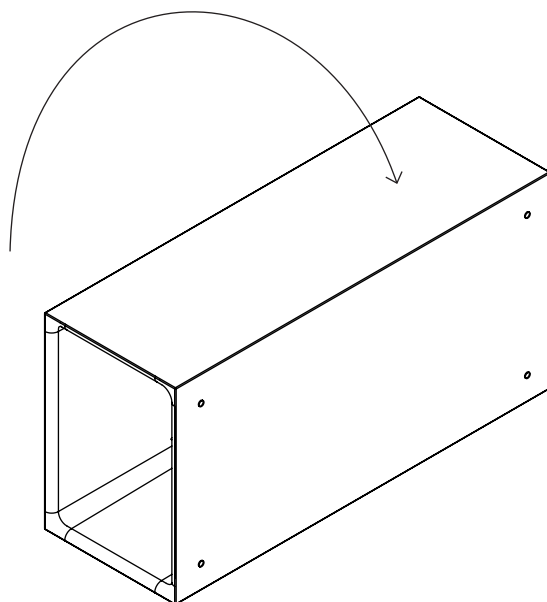

IT • RUOTARE NUOVAMENTE LA BASE INFERIORE NELLA POSIZIONE CORRETTA.

EN • ROTATE THE LOWER BASE BACK INTO THE CORRECT POSITION.

3

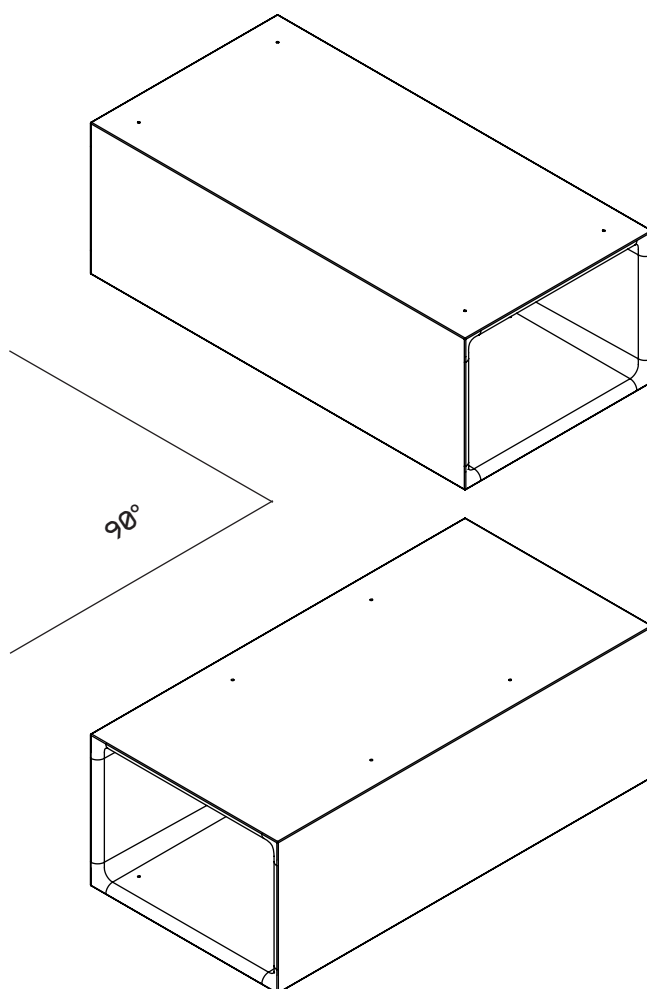

IT • POSIZIONARE LA BASE SUPERIORE A 90 GRADI RISPETTO QUELLA INFERIORE COME INDICATO.

EN • POSITION THE UPPER BASE AT 90 DEGREES TO THE LOWER ONE AS INDICATED.

4

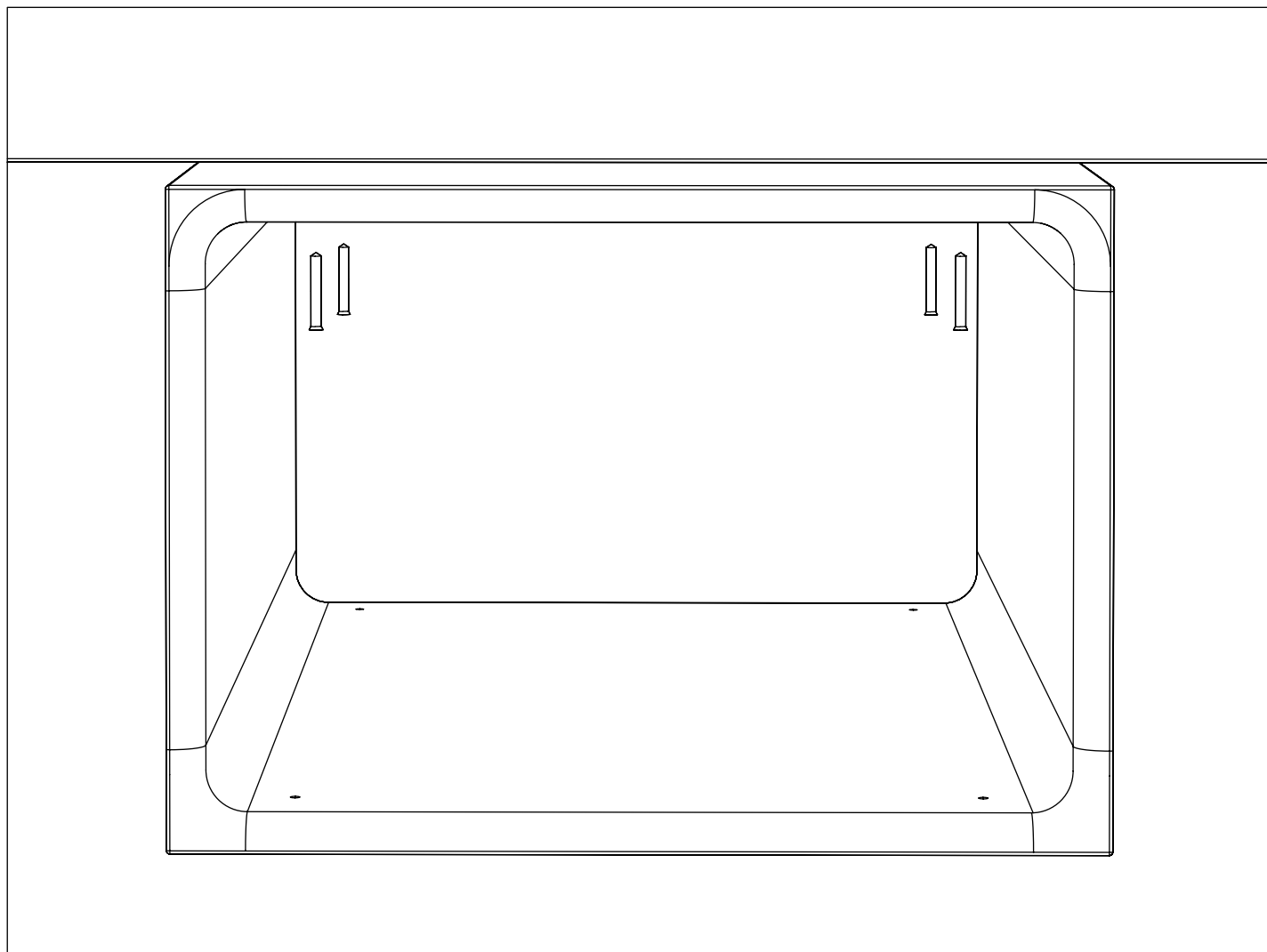

IT • INSERIRE LE VITI NEI FORI DELLA BASE INFERIORE ED AVVITARE.

EN • INSERT THE SCREWS INTO THE HOLES IN THE LOWER BASE AND TIGHTEN.

5

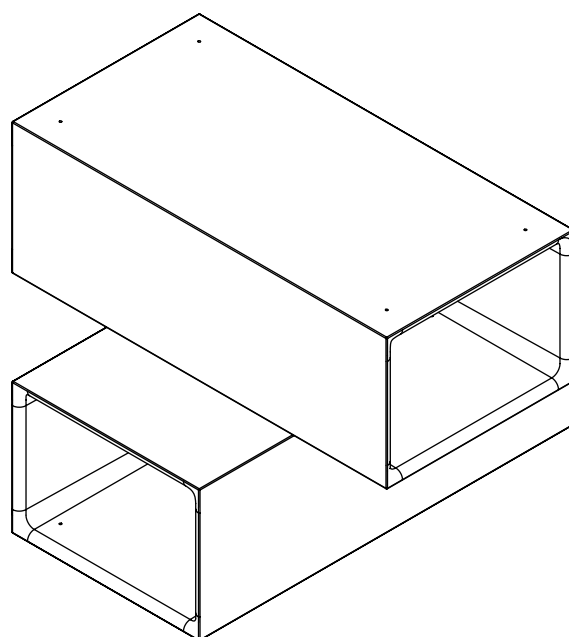
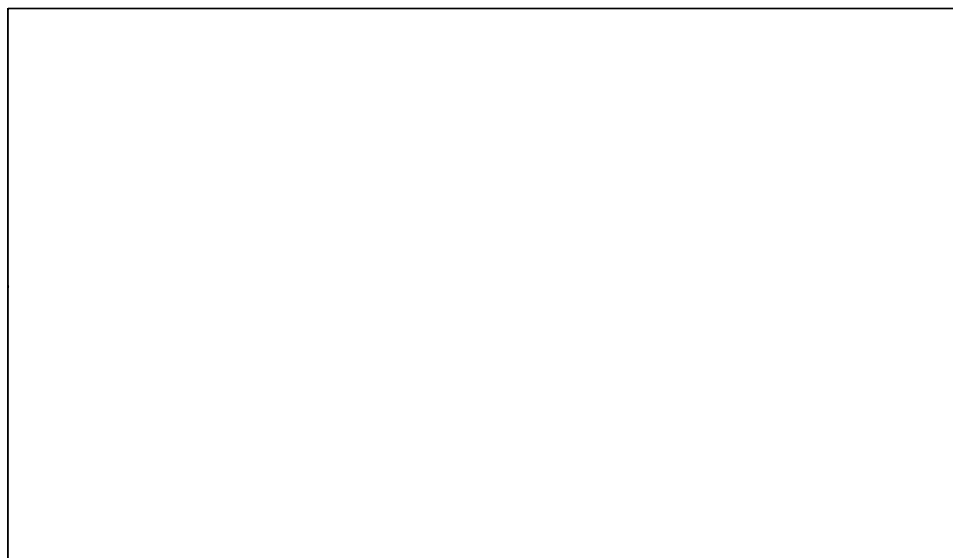

IT • CON ESTREMA CAUTELA POSIZIONARE IL PIANO SULLE BASI.

EN • PLACE THE TOP ON THE BASES WITH EXTREME CAUTION.

6

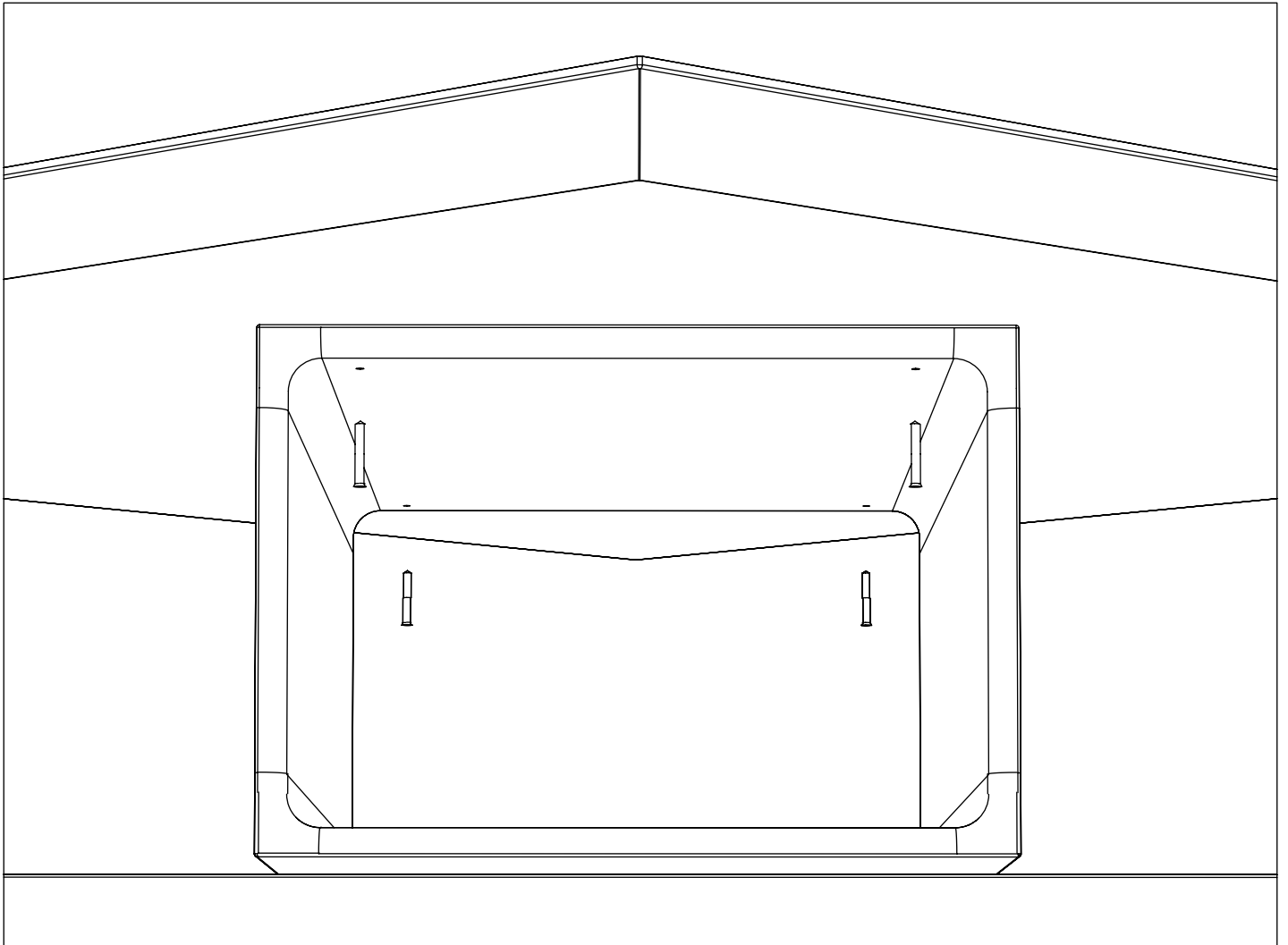

IT • INSERIRE LE VITI NEI FORI DELLA BASE SUPERIORE ED AVVITARE. ORA IL TAVOLO È FRUIBILE.

EN • INSERT THE SCREWS INTO THE HOLES IN THE UPPER BASE AND TIGHTEN. NOW THE TABLE IS USABLE.

Se dovessi avere problemi nell'assemblare il tuo prodotto, contattaci all'indirizzo info@pulkra.it. Siamo sempre felici di aiutarti!

Abbiamo selezionato attentamente i materiali utilizzati in questo prodotto e ti chiediamo di trattarlo con responsabilità. Ti preghiamo di riciclare tutto l'imballaggio secondo le norme locali di smaltimento.

Should you have any problems assembling your product contact us at info@pulkra.it. We're always happy to help! We have carefully selected the materials used in this product, and ask you to treat it responsibly too. Please recycle all packaging according to your local disposal rules.